

**OUTLINES OF AN LFG-XLE ACCOUNT
OF NEGATION IN HUNGARIAN
SENTENCES**

Tibor Laczkó
University of Debrecen

Proceedings of the LFG14 Conference

Miriam Butt and Tracy Holloway King
(Editors)

2014

CSLI Publications

<http://csli-publications.stanford.edu/>

Abstract

In this paper, partially motivated by É. Kiss (1992, 1994), I develop the core aspects of the first LFG analysis of constituent and predicate negation in Hungarian. My general framework is the approach to Hungarian finite sentences proposed in Laczkó (2014a). I concentrate on essential c-structural, functional annotational and lexical representational issues.

1 Introduction

In Laczkó (2014a), this volume, I present the basic ingredients of a comprehensive LFG analysis of the preverbal portion of Hungarian finite clauses (designed to be XLE-implementable). I propose a general formal apparatus for handling constituents in the topic and the quantifier fields and in the specifier position of the VP. I assume that focussed constituents, verbal modifiers (VMs) and question phrases are in complementary distribution in [Spec,VP]. In this paper, partially motivated by É. Kiss (1992, 1994), I develop the core aspects of the first LFG analysis of constituent and predicate negation in this model. I concentrate on c-structural, functional and lexical representational issues and leave semantic issues (including the treatment of negative polarity items and scope relations) to future research.

The structure of the paper is as follows. In section 2, I present the basic facts and the relevant empirical generalizations. In section 3, I give a critical overview of Payne and Chisarik's (2000) account in the framework of Optimality Theory (OT), the only relatively extensive LFG-friendly analysis of negation in Hungarian that I am aware of. In section 4, I present my analysis. I conclude in section 5.

2 The basic facts

In this section, I present and exemplify the basic empirical generalizations that need to be captured in a theoretically oriented approach. I capitalize on É. Kiss' (1992) overview of the relevant facts.

- A) There are two types of negation: constituent negation and predicate (sentence) negation.
- B) When an ordinary constituent is negated, it must obligatorily occupy the preverbal focus position. Such a constituent cannot occur anywhere else in the sentence.
- C) When a universal quantifier (UQ) is negated, there are two scenarios.
 - a. When there is no (other) focussed constituent in the sentence, the negated quantifier constituent must occupy the [Spec,VP] position (just like any ordinary negated constituent).

- b. When there is a focussed constituent in the sentence, the negated quantifier constituent has to be left-adjoined to the VP, just like ordinary non-negated quantifiers.

D) Sentence (predicate) negation has two varieties.

- a. The negative particle (NMR)¹ immediately precedes the verb, and the particle may or may not be preceded by a focussed constituent. If it is preceded by a focussed constituent, that constituent may or may not be negated.
- b. The NMR precedes a focussed constituent.

E) Double or even treble negation is also possible.

Consider the following examples, illustrating these construction types. The sentences contain a particle (= preverb) to demonstrate the fact that when a negated constituent immediately precedes the verb, it (at least in descriptive terms) occupies the customary focus position (because foci and particles are in complementary distribution preverbally).²

(1) **neutral affirmative sentence**

Péter fel hívta a barátját.
 Peter.NOM up called the friend.his-ACC
 'Peter called up his friend.'

(2) **non-neutral affirmative sentence (with focus)**

Péter A BARÁTJÁT hívta fel.
 Peter.NOM the friend.his-ACC called up
 'It was his friend that Peter called up.'

(3) **ordinary constituent negation**

Péter NEM A BARÁTJÁT hívta fel.
 Peter.NOM not the friend.his-ACC called up
 'It wasn't his friend that Peter called up.'

(4) **UQ negation without focus (= ordinary constituent negation)**

Péter NEM MINDENKI-T hívott fel.
 Peter.NOM not everybody-ACC called up
 'It wasn't everybody that Peter called up.'

(5) **UQ negation with focus**

Nem mindenki-t PÉTER hívott fel.
 not everybody-ACC Peter.NOM called up
 'It is not true for everybody that it was Peter that called them up.'

¹ In Hungarian the negative particle is *nem* 'not'. In order to avoid confusion with verbal particles (= preverbs), following Payne & Chisarik's (2000) terminology (see below), I refer to it as *negative marker*, abbreviated as NMR.

² FOCUSSED constituents are in SMALLCAPS.

- (6) **predicate negation, without focus, the NMR precedes the verb**
Péter nem hívta fel a barátját.
 Peter.NOM not called up the friend.his-ACC
 ‘Peter didn’t call up his friend.’
- (7) **predicate negation, with focus, the NMR precedes the verb**
PÉTER nem hívta fel a barátját.
 Peter.NOM not called up the friend.his-ACC
 ‘It was Peter who didn’t call up his friend.’
- (8) **predicate negation, with focus, the NMR precedes the focus**³
Péter nem A BARÁTJÁT hívta fel.
 Peter.NOM not the friend.his-ACC called up
 ‘It is not true that it was his friend that Peter called up.’
- (9) **double negation: constituent & predicate**
Péter NEM A BARÁTJÁT nem hívta fel.
 Peter.NOM not the friend.his-ACC not called up
 ‘It wasn’t his friend that Peter didn’t call up.’
- (10) **treble negation: UQ, constituent & predicate**
Nem mindenki-t NEM PÉTER nem hívott fel.
 not everybody-ACC not Peter.NOM not called up
 ‘It is not true for everybody that it wasn’t Peter that didn’t call them up.’

On the basis of (3) and (8), certain sentences can be ambiguous between ordinary constituent negation and (VP-type) predicate negation, respectively. This ambiguity is typically resolved prosodically (and/or contextually). In VP-type predicate negation, the NMR is unstressed, as a rule. In the case of constituent negation in focus, the default prosodic pattern is that the NMR carries the main stress of the constituent, but this is not necessarily so. However, when the NMR is unstressed and ambiguity arises, the context usually disambiguates.

³ As É. Kiss (1992) demonstrates, this is a very special construction type: two VPs with their respective foci are contrasted, and the first VP is negated. For instance, (8) would sound natural if it was continued by (i).

- (i) ... *hanem AZ APJÁ-NAK küldött email-t.*
 but the father.his-DAT sent email-ACC
 ‘but sent an email TO HIS FATHER.’

3 On Payne & Chisarik (2000)

In Laczkó (2014a) and in Laczkó (2014b), both in this volume, I summarize the most important aspects of previous LFG(-friendly) assumptions and proposals about the syntax of Hungarian finite clauses: Börjars et al. (1999), Mycock (2006), Gazdik (2012), Laczkó & Rákosi (2008-2014) and Laczkó & Rákosi (2011). The two overviews are in complementary distribution in the sense that only one of them discusses a particular approach at greater length. Both those papers point out that this paper offers a detailed discussion of Payne & Chisarik's (2000) analysis, because, in addition to verbal modifiers and focussed constituents, it also deals with negation phenomena. Thus, below I only offer an overview of this account, and for a discussion of the approaches mentioned above, the reader is referred to my other two papers in this volume. This critical overview is relatively detailed for the following reasons. (i) As far as I am aware, Payne & Chisarik's (2000) account is the only analysis of Hungarian negation phenomena in an LFG-compatible framework to date, so its empirical coverage, generalizations and solutions need to be discussed as a point of departure.⁴ (ii) Given that their proposed analysis is concerned with negation, focus, verbal modifiers and 'wh'-phrases, it is highly relevant for my other two papers in this volume. Its relatively detailed discussion then adds a further aspect to the complementarity of the overview of the relevant literature across these three papers.

Adopting the basic representational assumptions and ideas of Börjars et al. (1999), in their OT framework,⁵ Payne & Chisarik (2000) develop an analysis of Hungarian preverbal syntactic phenomena: the complementarity of constituent question expressions, focussed constituents, NMR and verbal modifiers. They use the following abbreviations: FOC = positive or negative focussed phrase, INT = interrogative phrase, NEG = negative phrase, NMR = negative marker, PART = (aspectual) particle (representing the entire class generally referred to as verbal modifiers (VMs)). NEG subsumes the following four types:⁶ INQ = inherently negative quantifier (e.g. *kevés* 'few'),

⁴ In section 4.1, I point out that Laczkó & Rákosi's (2008-2014) XLE grammar cannot appropriately handle even the most basic negation facts.

⁵ Although OT is compatible with a variety of generative frameworks, including LFG and GB/MP, the authors claim that their preferred model is LFG (2000: 206, fn. 10). This makes the discussion of their analysis here all the more important and at the relevant points I will compare their account with my approach from this perspective.

⁶ Notice that for Payne & Chisarik (2000) NEG does not subsume ordinary constituent negation. They simply assume that FOC can have affirmative and negative (negated) variants. Nor does the NEG symbol stand for the negative particle, because they represent it as NMR, and they assume that it is associated with the verbal head (even when the [Spec,VP] position is not filled) as in É. Kiss' (1994) analysis. When I present my analysis, I will claim that it is an intuitively more

INA = inherently negative adverb (e.g. *ritkán* ‘seldom’), NUQ = negated universal quantifier (e.g. *nem mindenki* ‘not everyone’), NCI = negative concord item (e.g. *senki* ‘nobody/anybody’).⁷

After presenting the basic empirical facts, they give a critical overview of three major types of approaches in the GB/MP tradition: (A) a VP analysis without functional projections like F(oc)P, see É. Kiss (1992, 1994), for instance; (B) unarticulated FP analysis, with a single functional projection, see Brody (1990, 1995), for instance; (C) articulated FP analysis, with multiple functional projections, see Puskás (1994, 1998), for instance.

The essence of Payne & Chisarik’s (2000) analysis is as follows. They assume the overall structure in (11) for the relevant portion of a Hungarian sentence.

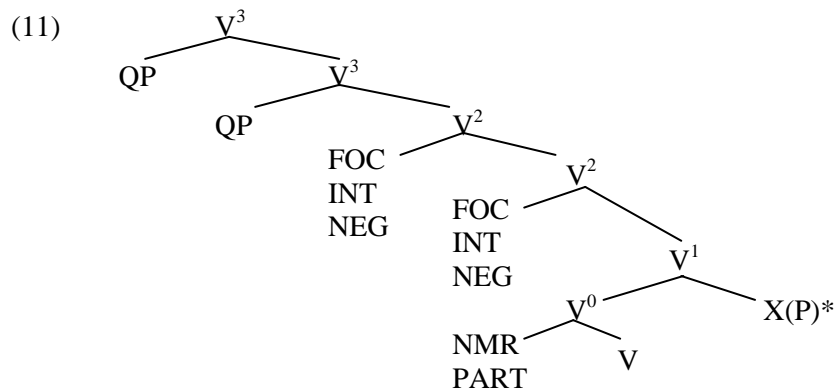

They do not postulate an ordinary VP constituent; instead, following Börjars et al. (1999), they employ a multilevel projection of the verb. In agreement with É. Kiss (1994), among others, they assume free word order in the postverbal domain (regulated, to a considerable extent, by semantic, prosodic and information structure factors in the form of tendencies). They write: “The assumption we shall make in this paper is that, from a purely syntactic point of view, the order of postverbal constituents is essentially free. This then entails an alternative account of the preverbal INT > FOC > NEG hierarchy” (2000: 200).

They propose the following ranking of OT constraints with respect to the preverbal position.

- (12) ALIGN INT > ALIGN FOC > ALIGN NEG > {ALIGN NCI, IN SITU}⁸

plausible option, at least from an LFG perspective, to assume that the negative marker can also fill [Spec,VP].

⁷ NCIs are also frequently called n-words.

⁸ The {ALIGN NCI, IN SITU} part of the ranking is intended to capture the generalization that, among the NEG types, NCIs only optionally compete for the verb-adjacent position.

This analysis captures several basic Hungarian syntactic facts.

(i) If there is a question phrase in the sentence then it will occupy the designated preverbal position, and not a focussed constituent or a negative phrase.⁹ Compare the examples in (13) and (14).

- (13) *Melyik könyv-et olvasta el CSAK JÁNOS?* **INT-FOC**
 which book-ACC read.PAST VM only John.NOM
- **CSAK JÁNOS olvasta el melyik könyv-et?* **FOC-INT**
 only John.NOM read.PAST VM which book-ACC
- ‘Which book did ONLY JOHN read?’
- (14) *Melyik könyv-et nem olvasta el senki?* **INT-NCI**
 which book-ACC not read.PAST VM nobody.NOM
- **Senki nem olvasta el melyik könyv-et?* **NCI-INT**
 nobody.NOM not read.PAST VM which book-ACC
- ‘Which book did nobody read?’

(ii) If a focussed constituent and a negative phrase compete, the former wins out, cf.:

- (15) *CSAK EZT KÖNYV-ET nem olvasta el senki.* **FOC-NCI**
 only this book-ACC not read.PAST VM nobody.NOM
- **Senki nem olvasta el CSAK EZT KÖNYV-ET.* **NCI-FOC**
 nobody.NOM not read.PAST VM only this book-ACC
- ‘Nobody read ONLY THIS BOOK.’

The alignment ranking in (12) is proposed to capture the complementarity of INT, FOC and NEG below V² in Payne & Chisarik’s (2000) structure in (11). They treat the NMR *nem* ‘not’ and verbal modifiers separately in the following way.

1. They assume that both NMR and VMs are morphologically incorporated into the verb when they precede it. The authors take preverbs (particles) to be the prototypical representatives of this categorially heterogeneous class,¹⁰ and they use the PART label for them.
2. NMR and PART are also in complementary distribution in a position dominated by V⁰, see (11), and the former is stronger in the competition.

⁹ A reminder: in their analysis, a negative phrase (NEG) has four types: INQ, INA, NUQ and NCI. In these examples an NCI is used.

¹⁰ On the basis of É. Kiss (1994), they mention the following additional VM types: postpositions, bare non-referential nouns, bare resultative adjectives and bare infinitives.

3. In order to capture the word order facts also involving the V^0 domain, Payne & Chisarik (2000) augment the constraint hierarchy in (12) in the following way.

(16) ALIGN INT > ALIGN FOC > ALIGN NEG > {ALIGN NCI, IN SITU} >
ALIGN V^0 > ALIGN NMR > ALIGN INCORP > {ALIGN V | *INCORP}

The extension aligns V^0 first if there are not stronger candidates in the preceding portion of the hierarchy, and the priority of the negative marker over the VM is encoded by the ALIGN NMR > ALIGN INCORP order.¹¹

My remarks on Payne & Chisarik's (2000) analysis are as follows.

1. Agreeing with both Börjars et al. (1999) and Payne & Chisarik (2000), I share the LFG-style rejection of functional categories like F(oc)P and TopP, for details, see Laczkó (2014a).
2. On the basis of the argumentation and considerations in Laczkó (2014a), I maintain that the postulation of a VP constituent with a single specifier position is tenable (and useful), and the relevant phenomena can be captured in a fully LFG framework, see Laczkó (2014a, 2014b), and it could also be captured in an OT (or OT-LFG) approach.
3. The NEG label very strongly invokes the notion of genuine (syntactic and/or morphological) negation. However, Payne & Chisarik's (2000) NEG basically subsumes "semantic negation": INQ, INA and negative concord elements (NCIs), which themselves do not encode negation. In this group, NUQs are formally (and semantically) really negated elements (and they are substantially different from all the other elements in this group in their distributional properties). Thus, this NEG label is rather misleading here. Moreover, if morpho-syntactic negation is taken seriously, the authors' INT > FOC > NEG hierarchy calls for some clarification and explanation. The reason for this is that an ordinary negated constituent has priority over an ordinary focussed constituent, cf.:

(17) *NEM A KÖNYV-ET olvasta el CSAK JÁNOS.*
not the book-ACC read.PAST VM only John.NOM
**CSAK JÁNOS olvasta el NEM A KÖNYV-ET.*
only John.NOM read.PAST VM not the book-ACC

cca. 'It wasn't the book such that it was only John that read it.'

Naturally, NEG in this OT hierarchy can be used in the way the authors do (with appropriate remarks); however, the contrast in (17) has to be captured in this framework as well.¹²

¹¹ INCORP stands for the preverbal morphological incorporation of VMs.

¹² In the authors' approach, both *nem a könyvet* 'not the book' and *csak János* 'only John' in (17) are treated as FOC elements, and this \pm neg dimension in this domain is not at all addressed.

4. I think the most serious problem with Payne & Chisarik's (2000) analysis is their treatment of VMs (and, to a smaller extent, the treatment of NMR) for the following reasons.
- a) Referring to É. Kiss (1994), they assume that both VMs and NMR are morphologically incorporated into the verb optionally.¹³ First of all, É. Kiss (1994) only assumes semantic incorporation of VMs even when they are preverbal, and she claims that even preverbally they are syntactically separate elements (occupying the [Spec,VP] position in her system). Secondly, É. Kiss (1994) does not incorporate the negative marker morphologically, either. Instead, she adjoins it to the verbal head.¹⁴
 - b) Of course, morphological incorporation could be an alternative solution, but this would require argumentation and supporting evidence. In Laczkó (2014b), I argue in a detailed fashion against the incorporation analysis of VMs in general.¹⁵
 - c) Even if we accept the morphological incorporation treatment, it raises a conceptual problem: Payne & Chisarik's (2000) alignment rules mix two dimensions, a syntactic level and a morphological level. This is a rather marked solution the nature of which would call for some independent support, on the one hand, and it would be an appealing alternative if no other (less marked) solution was available. And this latter requirement does not seem to be satisfied, see the next point.
 - d) Even if we disregard the syntax-morphology-mix issue and accept the analysis, it is important to see that Payne & Chisarik (2000) do assume two distinct positions for VMs and FOC et al. From this it follows that there is no radical conceptual difference between their idea and the (un)articulated GB/MP style FP analyses they criticize. They explicitly state that their alignment hierarchy has been designed to capture the preverbal complementarity of INT, FOC, NEG *and* VMs in such a way that VMs are the weakest candidates. Then it is rather questionable why VMs are assumed to occupy a different position at a distinct level of representation.
5. Payne & Chisarik (2000) subscribe to a popular view of the distribution (and complementarity) of focussed constituents and question expressions, on the one hand, and VMs, on the other hand. They assume that (i) the two types occupy two distinct preverbal syntactic positions and (ii) VMs are head-adjoined to the simplex verb and incorporation takes place, and, as a consequence (iii) the complementarity of the two types has to be

¹³ When they are left-adjacent to the verb, they are incorporated, and elsewhere they are independent syntactic elements.

¹⁴ By contrast, É. Kiss (1992) left-adjoins her NEG to V'. Obviously, É. Kiss' (1994) solution is an instance of head-adjunction, and É. Kiss' (1992) treatment is phrasal adjunction.

¹⁵ See point 5 below.

captured by special means. As I argue in a detailed fashion in Laczkó (2014b), the treatment of all types of VMs along the head-adjunction and incorporation lines is counterintuitive and untenable, because (a) some types are clearly maximal projections (so the postulation of head-adjunction is unavailable) and (b) some types clearly defy the assumption of any notion of incorporation. This is a general problem for any approach along these lines. However, as far as I can see, OT, Payne and Chisarik's (2000) chosen framework, would naturally provide the appropriate principles and devices to capture this famous complementarity in an intuitively more plausible way. It would be worth considering developing an OT analysis by postulating a single designated preverbal position and assuming that all the relevant constituents compete for this position and various violable constraints regulate their complementarity in that position. In Laczkó (2014b), I present an LFG analysis along the single designated position lines (with a system of various disjunctions of functional annotations), and it seems to me that this approach could also be translated into OT terms.

4 Towards an LFG-XLE analysis of negation

In subsection 4.1, I point out to what extent Laczkó & Rákosi's (2008-2014) XLE grammar can handle negation. In subsection 4.2, I briefly present the relevant details of the general sentence structural approach I propose in Laczkó (2014a), and in subsection 4.3, I outline my analysis of negation in this model.

4.1 On Laczkó & Rákosi (2008-2014)

In our XLE grammar, we have not yet implemented the analysis of negation to a satisfactory extent at all: basically, we only have a rudimentary treatment for testing purposes. The current state of affairs is as follows.

(A) Negation is neither uniformly nor consistently treated in various ParGram grammars. One of the central (and controversial) issues is the contribution of the negative marker (whether a bound or a free morpheme) to the f-structure of a sentence. The two basic options are as follows: (i) the marker is treated as an adjunct encoding negation (ii) the negative marker contributes a feature value: NEG +.¹⁶ In our grammar, we employ the first option (just like the English grammar, among others). We have the following lexical form for the negative marker *nem* 'not'.

¹⁶ For details and discussion, see the following web page and the documents there: <http://typo.uni-konstanz.de/redmine/projects/pargram/wiki/Negation/9>.

(18) *nem* ADV XLE @(PRED %stem)
 (^ ADJUNCT-TYPE)= neg.

The relevant portion of the f-structure of the sentence containing the negative marker looks like this.

(19) ADJUNCT { PRED 'nem'
 ADJUNCT-TYPE neg }

(B) Given the preliminary nature of our treatment of negation, the grammar gives a good parse for only one of the seven types of negative constructions presented in section 2: predicate negation, without focus, the NMR precedes the verb, see the example in (6). Even in this case, however, the system yields 13 parses (most of them being due to independent unconstrained aspects of the grammar), and only two are appropriate.

(C) It seems that one of the problems causing “overgeneration in parsing” is that we assume that the category of *nem* ‘not’ is ADV, see (18), and its use is not constrained enough in the current version of the implemented grammar. For instance, in one of the parses it treats the negative marker as an OBL.

4.2 On sentence structure in Laczkó (2014a)

In the spirit of Laczkó & Rákosi (2008-2014) and also partially inspired by É. Kiss (1992), in Laczkó (2014a) I assume the following skeletal sentence structure.¹⁷

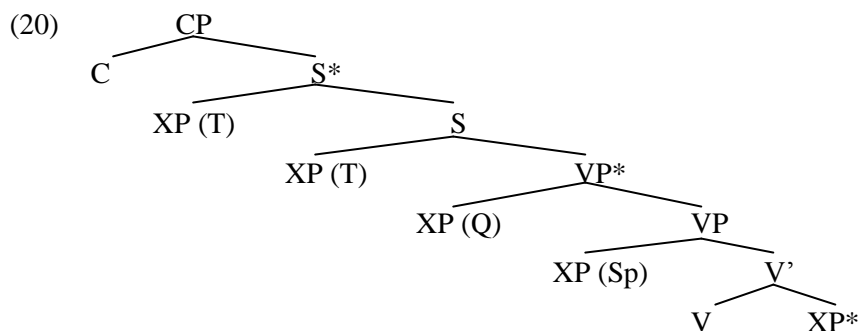

4.3 Outlines of an account of negation

In my analysis, I basically adopt É. Kiss’ (1994) structural approach to negation (in her GB framework), see the schematic representation in (21).

¹⁷ S* and VP* encode the possibility of multiple left-adjunction. The abbreviations are as follows: T = topic field, Q = quantifier field, Sp = [Spec,VP] position.

(21)

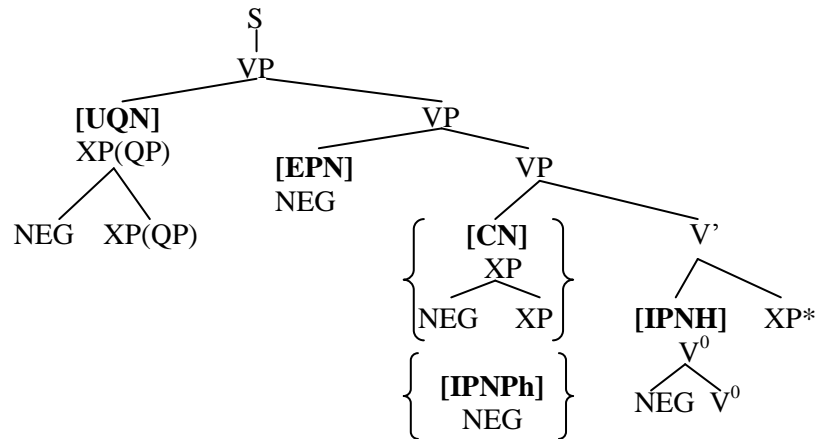

- A) The abbreviations in square brackets indicate the types of negation: [UQN] = universal quantifier negation, [EPN] = (VP)external predicate negation, [CN] = constituent negation, [IPNPh] = (VP)internal predicate negation, phrasal adjunction, [IPNH] = (VP)internal predicate negation, head-adjunction. The curly brackets signal the complementarity of [CN] and [IPNPh].
- B) The four negation positions are empirically justified; however, all the four cannot be simultaneously filled. Double negation is quite frequent, treble negation is very rare, quadruple negation is non-existent.¹⁸
- C) As I pointed out above, É. Kiss' (1992) analysis is different in one significant respect: it assumes that in the case of [IPN], a NegP is adjoined to V'. This approach is more uniform in the sense that it posits a phrasal status for the negative marker in all the positions it occurs in. It does not seem to be possible to choose between the two adjunction strategies in the [IPN] type on an empirical basis. Below I discuss some LFG-specific considerations that favour the head-adjunction analysis in the spirit of É. Kiss (1994), which allows the use of the negative marker as either a Neg or a NegP, see the next point.
- D) LFG's flexible assumptions about categories and their potential phrasal vs. non-phrasal status allow for the following three scenarios in the analysis of the negative marker in Hungarian. (i) It uniformly projects an

¹⁸ The main reason for these facts has to do with the increasing difficulty of processing multiple negation. Given that the adjunction of the negative marker to a VP with an obligatory focus is relatively rare, the combination of this construction type with a (preceding) VP-adjoined negated universal quantifier would be even more marked. So far, I have not come across any attested example of this kind. For this reason, I have simplified the phrase structure rules of my implemented grammar in such a way that the two VP-adjoined negative constituents are in complementary distribution. However, the efficient implementation of their non-complementary relation would not cause any technical problems, either.

XP (= NegP). This would be in accordance with É. Kiss' (1992) account. (ii) It can be used in the syntax as either an X⁰ or an XP category; and, thus, it can be either head-adjoined or phrase-adjoined. This would be in the spirit of É. Kiss (1994) in GB and Toivonen (2001) in her treatment of particles in LFG. (iii) It can be assumed to be a uniformly non-projecting word (capable of occurring in both X⁰ and XP positions), cf. the treatment of particles in English, German and Hungarian in Forst et al. (2010). Given the fact that this Hungarian negative marker does not exhibit any phrasal behaviour in its own right, i.e. it can never be modified, I adopt the third treatment here (and this is what I implemented when I tested my analysis, for details, see below). I hasten to add that nothing crucial hinges on this particular aspect of my account, and both of the other solutions are fully tenable both (LFG-)theoretically and implementationally (I have also tested their implementability). My choice of option (iii) was simply motivated by economy considerations: there is no empirical evidence for a phrasal projection of the negative marker. In future work, I plan to develop an LFG analysis of several Hungarian "small categories" that are arguably best treated as non-projecting words along these lines: verbal particles (aka verbal prefixes or coverbs), *csak* 'only', *ne* 'not' in prohibitions, *nem* 'not', *is* 'also', *sem* 'also not', *volna* (the marker of irrealis mood), *-e* (the yes-no question marker), etc.

- E) In my implemented rules, I use the NEG category label (as opposed to Laczkó & Rákosi's (2008-2014) ADV), which contributes greatly to parsing parsimony.
- F) As (21) shows, in my analysis NEG can occupy three major types of syntactic positions: it can be in [Spec,VP] and it can also be either head-adjoined or phrase-adjoined.
- G) In all the three cases, it has the ADJUNCT annotation.
- H) My lexical form for the negative marker is as follows. Compare this with (18).¹⁹

(22) *nem* NEG * @ (PRED %stem)
 (^ ADJUNCT-TYPE)= neg.

- I) The special NEG category, the specific phrase structure rules and the functional annotations in this analysis jointly ensure full parsing

¹⁹ In (18) the lexical form contains XLE after the category specification. This prompts Laczkó & Rákosi's (2008-2014) implemented grammar to use the information provided by the (fst) morphological analyzer. In this case it will utilize the +Adv tag for *nem* coming from the fst. By contrast, the * symbol in (22) blocks the fst, and the grammar only uses the information included in the lexical form of the given word. This is the simplest way of introducing a special category. The fact that the fst cannot "see" it is no problem at all, given that this word has only a single morphological form.

efficiency. The implemented grammar only produces the expected parses in the case of all the negated constructions under investigation.

Let us now see the details of the analysis of each construction type. For convenience, below I repeat the relevant examples from section 2.

4.2.1 Constituent negation

As has been demonstrated in section 2, standard constituent negation targets the preverbal position ([Spec,VP] in É. Kiss' (1992, 1994) and my analysis), see [CN] in (21) and the relevant example in (3). If an ordinary constituent is negated, this is the only syntactic position available for it.

- (3) **ordinary constituent negation**
Péter *NEM A BARÁTJÁ-T* *hívta fel.*
 Peter.NOM not the friend.his-ACC called up
 'It wasn't his friend that Peter called up.'

In my analysis of this construction type, I use the following c-structure rules. I augment the { XP | PRT } disjunction with the following disjunct for the [Spec,VP] position.

- (23) XPneg: (^ GF)=! (^ FOCUS)=!

In addition, I have the following rule for negated constituents.

- (24) XPneg --> NEG: @ADJUNCT;
 XP.

Consider the XLE c-structure and f-structure of (3) in Figures 1 and 2 (next page). As Figure 2 shows, only the negated OBJ DP is in the scope of the negative marker: the marker is represented as the negative adjunct of the OBJ. The negated constituent has the FOCUS DF, which is an empirically correct generalization. As (4) demonstrates, a negated universal quantifier can also occur in this position.

- (4) **UQ negation without focus (= ordinary constituent negation)**
Péter *NEM MINDENKI-T* *hívott fel.*
 Peter.NOM not everybody-ACC called up
 'It wasn't everybody that Peter called up.'

The analysis is the same.²⁰

²⁰ It has to be constrained, though, that non-negated universal quantifiers are banned from this position.

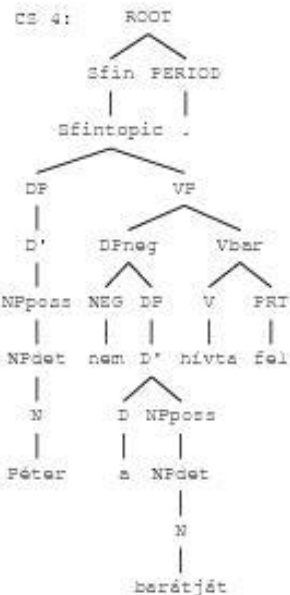

Figure 1: c-str. of (3)

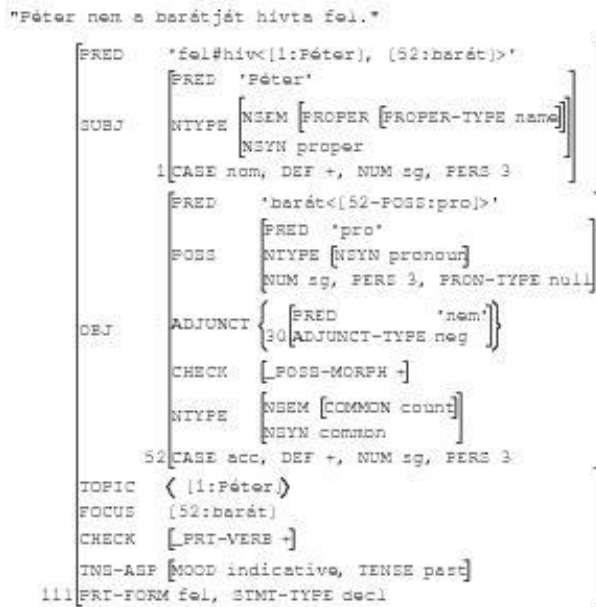

Figure 2: f-str. of (3)

When there is an ordinary focussed constituent present (which obligatorily fills the [Spec,VP] position), the negated universal quantifier can (or, rather, must) occupy a VP-adjoined position in the “quantifier zone”, see [UQN] in (21) and the example in (5).

(5) *UQ negation with focus*

Nem mindenki-t PÉTER hívott fel.
 not everybody-ACC Peter.NOM called up
 ‘It is not true for everybody that it was Peter that called them up.’

I employ the following VP-adjunction rule.

- (25) VPneg --> XPneg: (^ GF)=!
 (^ FOCUS)
 (! QUANT-TYPE) =c universal;
 VP.

The annotations associated with XPneg capture the relevant empirical generalizations. Only negated universal quantifiers can be adjoined to the VP, and the VP has to contain a focus. Consider the c-structure and f-structure of (5) in Figures 3 and 4 (next page).

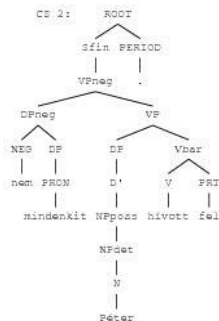

Figure 3: c-str. of (5)

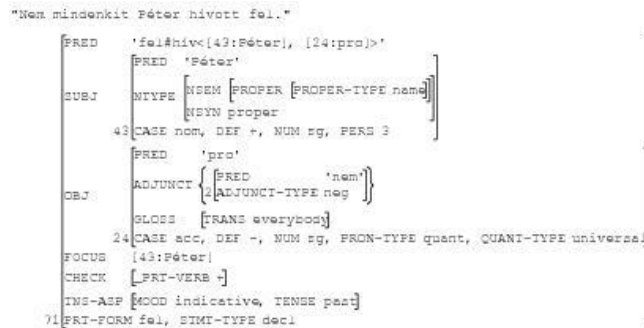

Figure 4: f-str. of (5)

2 Predicate negation

As I demonstrated in section 2, when there is a focussed constituent in a sentence, there are two varieties of negation: (i) the negative marker precedes the focussed constituent (ii) the negative marker follows the focussed constituent.

Structurally, I treat (i) as É. Kiss (1992, 1994): I assume that NEG is adjoined to VP, see the [EPN] constituent in (21) and the example in (8).

- (8) *predicate negation, with focus, the NMR precedes the focus*
Péter nem A BARÁTJÁ-T hívta fel.
 Peter.NOM not the friend.his-ACC called up
 ‘It is not true that it was his friend that Peter called up.’

I use the following phrase structure rule in this case.²¹

- (26) VPneg --> NEG: @ADJUNCT (^ FOCUS);
 VP.

Consider the c-structure and f-structure of (8) in Figures 5 and 6 (next page).

²¹ As I pointed out above, although it is possible, in principle, to have the combination of VP-adjoined universal quantifier negation and VP-adjoined predicate negation, no real examples have been attested; therefore, in the current version of my implemented grammar I use the two VP-adjunction rules in complementary distribution by collapsing (25) and (26) disjunctively:

- (i) VPneg --> { NEG: @ADJUNCT (^ FOCUS)
 | DPneg: @DP-GF (^ FOCUS) (! QUANT-TYPE) =c universal }
 VP.

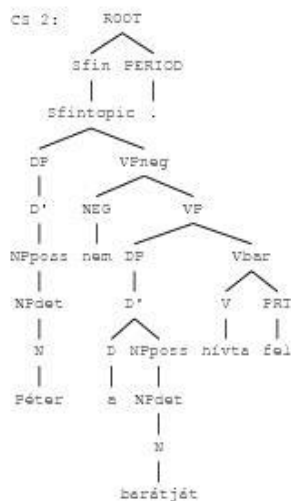

Figure 5: c-str. of (8)

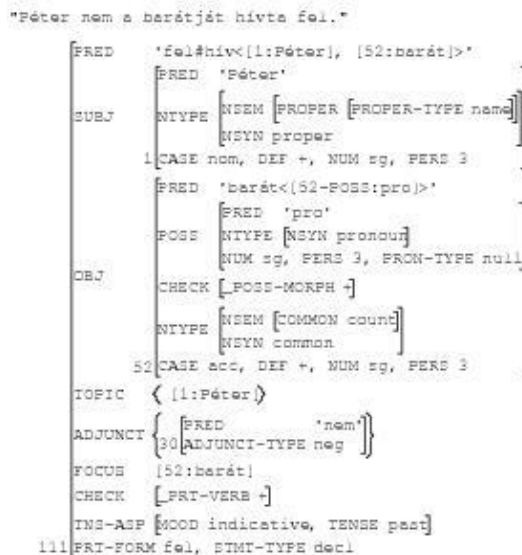

Figure 6: f-str. of (8)

Notice that in the f-structure representation the sentence is in the scope of the negative marker (neg ADJUNCT).²²

I handle the (ii) predicate negation type illustrated in (7) as É. Kiss (1994), contra É. Kiss (1992).

- (7) *predicate negation, with focus, the NMR precedes the verb*
 PÉTER nem hívta fel a barátját.
 Peter.NOM not called up the friend.his-ACC
 'It was Peter who didn't call up his friend.'

É. Kiss (1994) head-adjoins Neg⁰ to V⁰, and here I make the same assumption, see the [IPNH] constituent in (21). Let me add that the adjunction of NegP to V' would also be an absolutely legitimate solution;²³ moreover, it can even be someone's preferred solution in LFG if, in cases

²² As I pointed out in section 2, a sentence can be ambiguous between ordinary constituent negation and the VP-adjunction type of predicate negation, cf. (3) and (8).

²³ It is noteworthy that in the GB/MP tradition the status of the two solutions in É. Kiss (1992) and É. Kiss (1994) has kept changing. Originally both were legitimate in their respective GB contexts. Later adjunction was only acceptable as either head (X⁰) adjunction or maximal projection (XP) adjunction. In this new light É. Kiss' (1992) solution would have been out. In the MP paradigm of functional projections, both adjunction treatments are outdated. The current standard approach is the postulation of a NegP whose Neg head takes the constituent to be negated as its complement, see É. Kiss (2002), for instance.

like this, they reject the idea of head-adjunction in general and the notion of non-projecting words in particular.

My head-adjunction rule is as follows.

- (27) Vneg --> NEG: @ADJUNCT
 (^ FOCUS);
 V.

Consider the structures for (7) in Figures 7 and 8.

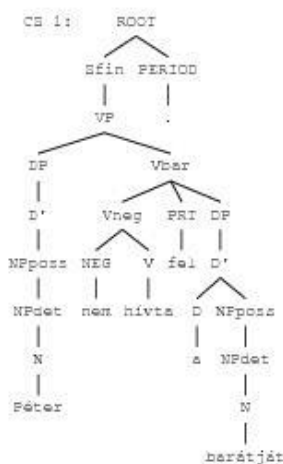

Figure 7: c-str. of (7)



Figure 8: f-str. of (7)

The third type of predicate negation is when (at least in descriptive terms) the negative marker seems to be in complementary distribution with VMs and other [Spec,VP] elements (i.e. focussed and 'wh'-phrases): there is no focussed constituent or 'wh'-phrase in the sentence, the negative marker precedes the verb and the VM must occur postverbally, see the example in (6).

- (6) **predicate negation, without focus, the NMR precedes the verb**
Péter nem hívta fel a barátját.
 Peter.NOM not called up the friend.his-ACC
 'Peter didn't call up his friend.'

For É. Kiss (1992, 1994) this is the same case as (ii) above: the [Spec,VP] position is not filled (by either a focussed constituent or a 'wh'-phrase), and NegP/Neg is adjoined to V'/V⁰. É. Kiss claims that the reason why a VM occurs (i.e. remains) in its base-generated postverbal position is that it has to be in the scope of negation. Although this solution could be accommodated

in my LFG account, here I propose that in these constructions the NegP occupies the [Spec,VP] position. My main motivation for this treatment is that it most straightforwardly captures the complementarity of all the four major types of preverbal constituents, which is in full accord with LFG's what-you-see-is-what-you-get principle.

The relevant rule is very simple. I augment the [Spec,VP] disjunction with the following disjunct: NEG: @ADJUNCT (^ FOCUS)=!. The resulting disjunction (simplified for our present purposes) is as follows.

- (28) { PRT
 | XP (^ GF)=! (^ FOCUS)=!
 | XPneg: (^ GF)=! (^ FOCUS)=!
 | NEG: @ADJUNCT (^ FOCUS)=! }

Consider the structures for (6) in Figures 9 and 10.

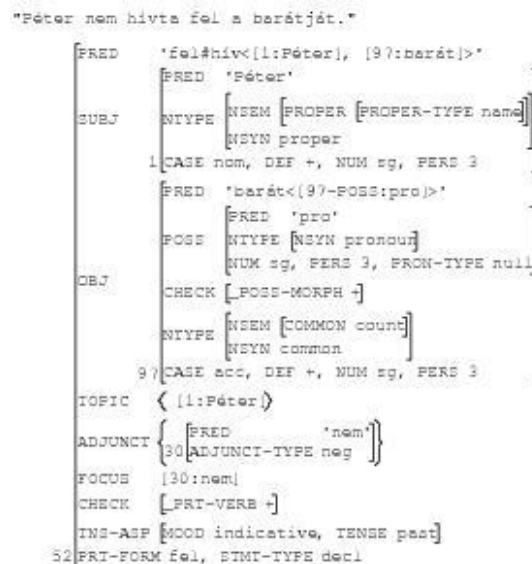
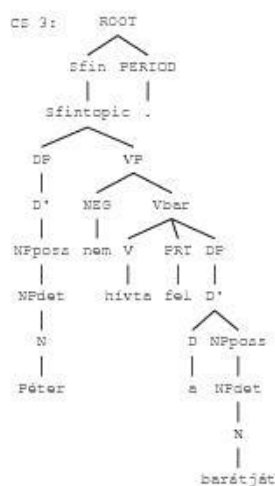

Figure 9: c-str. of (6)

Figure 10: f-str. of (6)

Notice that in this case I assume that NEG in [Spec,VP] is focussed. On the one hand, I think this is plausible intuitively (NEG very often gets heavy stress), and, on the other hand, I need this specification for the proper treatment of the postverbal occurrence of VMs.

5 Concluding remarks

In this paper, I have presented an LFG-XLE analysis of basic negation phenomena in Hungarian finite clauses in the framework of my general approach proposed in Laczko (2014a). The account has been successfully implemented and tested.

The following (further) details of the analysis are yet to be developed:

- the behaviour of NCIs – with particular attention to the issues discussed in my overview of Payne & Chisarik's (2000) analysis;
- the dual function of *sem* 'also not', which, in combination with ordinary constituents and NCIs, can (i) express 'also' in an NCI environment and (ii) perform the role of the negative marker *nem* 'not' (with an additional element of meaning: 'also');
- scope relationships in general and in multiple negation in particular;
- the XLE implementation of these further aspects of the account on Laczko & Rákosi's (2008-2014) HunGram platform.

Acknowledgements

I thank the participants of the LFG14 conference for useful remarks and Louise Mycock for a very useful discussion. I am especially grateful to my anonymous reviewers, because their comments motivated my developing and implementing an alternative analysis presented in this final version of the paper. Any errors that remain are solely mine.

The research reported here was supported by the OTKA (*Hungarian Scientific Research Fund*) project entitled *Comprehensive Grammar Resources: Hungarian* (grant number: NK 100804).

References

- Börjars, Kersti, Payne, John & Chisarik, Erika. 1999. On the justification for functional categories in LFG. In: Butt, Miriam. & King, Tracy. H. eds. *Proceedings of the LFG99 Conference*. University of Manchester. Stanford: CSLI Publications.
- Brody, Michael. 1990. Remarks on the order of elements in the Hungarian focus field. In: Kenesei, István. ed. *Approaches to Hungarian. Volume 3. Structures and Arguments*. Szeged: JATE, 95-122.
- Brody, Michael. 1995. Focus and checking theory. In: Kenesei, István. ed. *Approaches to Hungarian. Volume 5. Levels and Structures*. Szeged: JATE, 29-43.
- É. Kiss, Katalin. 1992. Az egyszerű mondat szerkezete [The structure of the simple sentence]. In: Kiefer, Ferenc. ed. *Strukturális magyar nyelvtan 1. Mondattan*. [Structural Hungarian grammar 1. Syntax]. Budapest: Akadémiai Kiadó, 79-177.

- É. Kiss, Katalin. 1994. Sentence structure and word order. In: Kiefer, Ferenc & É. Kiss, Katalin. eds. *The Syntactic Structure of Hungarian*. New York: Academic Press, 1-90.
- É. Kiss, Katalin. 2002. *The Syntax of Hungarian. Cambridge Syntax Guides*. Cambridge: Cambridge University Press.
- Forst, Martin; King, Tracy H. & Laczkó, Tibor. 2010. Particle verbs in computational LFGs: Issues from English, German, and Hungarian. In Butt, Miriam & King, Tracy H. eds. *Proceedings of the LFG '10 Conference*. On-line publication. Stanford: CSLI Publications, 228-248.
- Gazdik, Anna. 2012. Towards an LFG analysis of discourse functions in Hungarian. In: Kiefer, Ferenc. & Bánréti, Zoltán. eds. *Twenty Years of Theoretical Linguistics in Budapest*. Budapest: RIL HAS & Tinta Könyvkiadó, 59-92.
- Laczkó, Tibor. 2014a. Essentials of an LFG analysis of Hungarian finite sentences. *This volume*.
- Laczkó, Tibor. 2014b. An LFG analysis of verbal modifiers in Hungarian. *This volume*.
- Laczkó, Tibor & Rákosi, György. 2008-2014. *HunGram. An XLE Implementation*. University of Debrecen.
- Laczkó, Tibor & Rákosi, György. 2011. On particularly predicative particles in Hungarian. In Butt, Miriam & King, Tracy H. eds. *Proceedings of the LFG '11 Conference*. Stanford: CSLI Publications, 299-319.
- Mycock, Louise. 2006. *A New Typology of Wh-Questions*. Ph.D. dissertation, University of Manchester.
- Payne, John & Chisarik, Erika. 2000. Negation and focus in Hungarian: An Optimality Theory account. In: *Transactions of the Philological Society* 98: 185-230.
- Puskás, Genovéva. 1994. Sentential negation in Hungarian. *Rivista di Linguistica* 6, 5-38.
- Puskás, Genovéva. 1998. On the neg-criterion in Hungarian. *Acta Linguistica Hungarica* 45, 167-213.
- Toivonen, Ida. 2001. *The Phrase Structure of Non-Projecting Words*. Ph.D. dissertation, Stanford University.